

DEVELOPMENT OF SOLAR-POWERED AUTOMATED TYROLEAN SPRAYER FOR TEACHING FINISHING IN BRICK/BLOCK LAYING AND CONCRETING IN TECHNICAL COLLEGES IN NORTH-CENTRAL NIGERIA

Zang, Emmanuel Christopher¹, Prof. Hassan Bello², Dr. Haruna Angulu³ & Dr. Samaila Hamza⁴

^{1,3&4}*Department of Construction Technology Education, Abubakar Tafawa Balewa University
Bauchi State*

²*Department of Electrical/ Electronics Technology Education, Abubakar Tafawa Balewa
University Bauchi State*

Corresponding Email: emmanuelizangc@gmail.com

ARTICLE INFO

Article No.: 0325

Accepted Date: 22/04/2026

Published Date: 10/05/2026

Type: Research

ABSTRACT

This study focuses on the development of Solar-Powered Automated Tyrolean Sprayer (SPATS) for teaching finishing techniques in brick/block laying and concreting in technical c in North-Central Nigeria. The increasing demand for practical skill acquisition in building construction requires innovative instructional tools that are efficient, and cost-effective. The study adopted Research and Development (R&D) research design. R&D research design is about creating, testing, and improving a working solution. The SPATS was powered using solar energy to ensure usability in areas with unreliable electricity supply. Major components of the sprayer include a photovoltaic panel, battery storage system, control unit among others. The constructed sprayer demonstrated efficiency, uniformity of spray, coverage of a large area within a short time, and ease of operation. The study concluded that the SPATS is a finishing system for improving practical teaching and learning of finishing in building construction. It is therefore recommended that technical colleges adopt the device to enhance skill acquisition.

Keywords: Development, Solar energy, Automated Tyrolean Sprayer, Finishing, Technical Colleges, North-Central Nigeria.

Introduction

Development is a structured and iterative process that involves conceptualization, design, construction, and refinement of a system or product. According to Akinwale and Ogundari (2017), development refers to the process of designing, constructing, and refining a product, model, or system; thereby bridging the gap between abstract ideas and real-world solutions. It often follows a systematic methodology, ensuring that each stage contributes to achieving the overall objective. The development practice has become fundamental components of modern research, especially in technical, vocational, engineering, and educational fields. Human civilization itself has evolved through the continuous development of tools, systems, and processes aimed at solving practical problems. According to Musa (2022), development has been driven by the need to improve efficiency, productivity, and quality of life, leading to the emergence of structured development processes and systematic procedures. The major phases of development of Solar-Powered Automated Tyrolean Sprayer are: design, component requirement and construction.

Design is the concept or proposal for an object, process, or system. The word, design, refers to something that is or has been intentionally created by a thinking agent, although it is sometimes used to refer to the inherent nature of something. According to Ogundero et al (2024), design is an applied endeavour: to design something one must have extensive knowledge of the thing being designed the major principles of designed according to Nwankwo (2021) are: contrast, rhythm, and pattern. Designing Solar-Powered Automated Tyrolean Sprayer, obviously have some learning goal, such as learning about speed efficacy among others, most design disciplines have various models or theories intended to help in the design process (Musa, 2022). The design factors put into consideration the following: cost, production efficiency, size of the product, rigidity of the system, strength of materials, and ease of handling safety. According to Ogundero et al (2024), efficiency is a crucial design factor considered in the design of any functional System such as the Solar-Powered Automated Tyrolean Sprayer.

Solar-Powered component is any part or device that is used in a system which generates and uses energy from sunlight (solar energy). These components work together to capture, convert, store, and use energy from the sun (Akinwale & Ogundari, 2017). The Solar-Powered Automated Tyrolean Sprayer consists of the following component/materials: Solar panel, solar charger controller, deep circuit battery, DC motor, motor controllers, hopper, flicker gun, chine and sprocket, wheel, bolt and nut, bearing, rail, based, sensor and metal, the components are available in the market at an affordable price.

Construction procedure starts from the planning stage of construction to the finishing of the object; it is influence by the mode of constructions in shape materials and functionality (Hurst, 2018). Construction procedure of Solar-Powered Automated Tyrolean sprayer is a series of step involved in the construction of SPATS. Construction procedure according to Musa (2022) includes: sketching, marking, cutting, drilling, welding/assembling, finishing and maintenance procedure. Sheet metal is used to make patterns for many objects; the metal is shaped by bending, folding, or rolling and fastened by riveting, seaming, soldering, or welding, Solar-powered energy connection among others.

Solar-powered energy refers to the conversion of sunlight into usable energy, typically electricity or heat, using technologies such as photovoltaic (PV) cells and solar thermal systems. As a renewable and sustainable energy source, solar energy plays a critical role in addressing global energy challenges, including fossil fuel depletion, environmental degradation, and climate change (Okoye, 2020). Solar-powered energy is widely studied due to its potential to provide clean, affordable, and reliable energy system such as: Tyrolean Automated Sprayer, for

finishing work, especially in developing countries like Nigeria where access to electricity remains limited in rural and semi-urban areas.

Finishing constitutes a critical phase that determines not only the aesthetic appeal of structures but also their durability and functionality. Finishing operations in brick/block laying and concreting such as plastering, rendering and surface texturing require precision, consistency, and efficiency (Smith, 2019). One commonly used finishing technique is Tyrolean, which involves spraying mortar or finishing materials onto wall surfaces to achieve a textured appearance that enhances both structural protection and visual quality (Ugochukwu, 2021). This technique is increasingly adopted to improve the overall integrity of building facades in Technical Colleges in North-Central Nigeria.

Statement of the Problem

Poor workshop facilities, lack of functional equipment, and limited access to modern tools hinder effective teaching and learning of Tyrolean finishing in technical colleges. Despite the growing global shift toward renewable energy technologies, particularly solar energy, and its application in construction, training tools remains limited in technical colleges; therefore, there is a need to develop a Solar-Powered Automated Tyrolean Sprayer that is cost-effective, efficient, and suitable for teaching finishing in brick/block laying and concreting. According to Okoye (2020), solar energy system in teaching enhances practical instruction, improve students' skill acquisition and provide a sustainable solution to the challenges of power supply and equipment inadequacy.

This study is therefore, to develop a Solar-Powered Automated Tyrolean Sprayer as a technological innovation to improve efficiency, reduce labor dependency, and enhances the quality of teaching finishing in technical colleges in North-Central Nigeria.

Purpose of the Study

The main purpose of this study is to:

1. Design a Solar-Powered Automated Tyrolean Sprayer for teaching finishing in brick/block laying and concreting in technical colleges in North-Central Nigeria
2. Determine the Component Requirements of Solar-Powered Automated Tyrolean Sprayer for Teaching Finishing in brick/block laying and concreting in technical colleges in North-Central Nigeria.
3. Construct a Solar-Powered Automated Tyrolean Sprayer for teaching finishing in brick/block laying and concreting in technical colleges in North-Central Nigeria

Research Questions

1. What are the Design criteria for the Development of Solar-Powered Automated Tyrolean Sprayer for Teaching finishing in brick/block laying and concreting in technical colleges in North-Central Nigeria?
2. What are the Component Requirements for the Development of Solar-Powered Automated Tyrolean Sprayer for teaching finishing in brick/block laying and concreting in technical colleges in North-Central Nigeria?
3. What are the Construct procedures for the Development of Solar-Powered Automated Tyrolean Sprayer for teaching finishing in brick/block laying and concreting in technical colleges in North-Central Nigeria?

Materials and Methods

Various materials and equipment were used for the Development of Solar-Powered Automated Tyrolean Sprayer, as well as the design structure and sequence of the various activities carried out in the construction process Research and development research design was used for the study. A number of equipment and materials, obtained from different sources, were

used during the construction process. Machine tools such as: Welding machine, grinding machine, spanners, screwdrivers, measuring tape was used in the construction. The design calculations ensured that the Solar-Powered Tyrolean finishing sprayer operates efficiently and suitable for finishing work.

Result

Questions 1: What are the Design criteria for the Development of Solar-Powered Automated Tyrolean Sprayer for teaching finishing in brick/block laying and concreting in technical colleges in North-Central, Nigeria?

The key design criteria that guided the development of an efficient, reliable, and cost-effective of Solar-Power Automated Tyrolean Sprayer using engineering design analysis are:

- i. Solar powered Automated Tyrolean Sprayer Specifications: Size, Shape consistent and efficiency, Frame Strength, Ease of Assembly/Disassembly.
- ii. Spraying Force: Must be adequate to ensure strength
- iii. Interchange ability: Ability to switch on and off.
- iv. Material: High-strength, wear-resistant steel
- v. Production Efficiency: Time Ideally 4 –6 working hours, ease of operation.
- vi. Power & Energy Considerations: Solar energy.
- vii. Material Handling: Input Feeding System (Hopper), output Handling (Tyrolean gun)
- viii. Durability and Safety Maintenance: corrosion resistance, lubrication, Safety Guards, emergency Stops. Operator Ergonomics

Design Calculation: The required power and energy for both the minimum and maximum material output scenarios, considering the system efficiency and safety factor
Minimum Material Output (0.5 m³/hour)

Calculate the mass flow rate (\dot{m}): $\dot{m} = \text{Volume flow rate} \times \text{Density} = 0.5 \text{ m}^3/\text{hour} \times 1600 \text{ kg/m}^3 = 800 \text{ kg/hour}$.

Convert to kg/s: $\dot{m} = 800 \text{ kg/hour} / 3600 \text{ s/hour} \approx 0.222 \text{ kg/s}$

Calculate the potential energy increase per second (Power required for lifting): Power lifting = $\dot{m} \times g \times h = 0.222 \text{ kg/s} \times 9.81 \text{ m/s}^2 \times 10 \text{ m} \approx 21.8 \text{ W}$

For system efficiency: Power input = Power lifting / Efficiency : Minimum Efficiency (70%):
Power input = $21.8 \text{ W} / 0.70 \approx 31.1 \text{ W}$.

Maximum Efficiency (80%): Power input = $21.8 \text{ W} / 0.80 \approx 27.3 \text{ W}$.

Apply the safety factor: Minimum Efficiency (70%): Power required = $31.1 \text{ W} \times 1.5 \approx 46.7 \text{ W}$

Maximum Efficiency (80%): Power required = $27.3 \text{ W} \times 1.5 \approx 41.0 \text{ W}$

Calculate the daily energy requirement (for 3-5 hours of operation):

Minimum Efficiency (70%): 3 hours: Energy = $46.7 \text{ W} \times 3 \text{ hours} = 140.1 \text{ Wh} \approx 0.14 \text{ kWh}$
5 hours: Energy = $46.7 \text{ W} \times 5 \text{ hours} = 233.5 \text{ Wh} \approx 0.23 \text{ kWh}$

Maximum Efficiency (80%): 3 hours: Energy = $41.0 \text{ W} \times 3 \text{ hours} = 123.0 \text{ Wh} \approx 0.12 \text{ kWh}$
5 hours: Energy = $41.0 \text{ W} \times 5 \text{ hours} = 205.0 \text{ Wh} \approx 0.21 \text{ kWh}$

Maximum Material Output (1.0 m³/hour)

Calculate the mass flow rate (\dot{m}): $\dot{m} = \text{Volume flow rate} \times \text{Density} = 1.0 \text{ m}^3/\text{hour} \times 1600 \text{ kg/m}^3 = 1600 \text{ kg/hour}$
Convert to kg/s: $\dot{m} = 1600 \text{ kg/hour} / 3600 \text{ s/hour} \approx 0.444 \text{ kg/s}$

Calculate the potential energy increase per second (Power required for lifting): Power lifting = $\dot{m} \times g \times h = 0.444 \text{ kg/s} \times 9.81 \text{ m/s}^2 \times 10 \text{ m} \approx 43.6 \text{ W}$

For system efficiency:

Minimum Efficiency (70%): Power input = $43.6 \text{ W} / 0.70 \approx 62.3 \text{ W}$

Maximum Efficiency (80%): Power input = 43.6 W / 0.80 ≈ 54.5 W

Apply the safety factor: Minimum Efficiency (70%): Power required = 62.3 W × 1.5 ≈ 93.5 W

Maximum Efficiency (80%): Power required = 54.5 W × 1.5 ≈ 81.8 W

Calculate the daily energy requirement (for 3-5 hours of operation):

Minimum Efficiency (70%): 3 hours: Energy = 93.5 W × 3 hours = 280.5 Wh ≈ 0.28 kWh

5 hours: Energy = 93.5 W × 5 hours = 467.5 Wh ≈ 0.47 kWh

Maximum Efficiency (80%): 3 hours: Energy = 81.8 W × 3 hours = 245.4 Wh ≈ 0.25 kWh

5 hours: Energy = 81.8 W × 5 hours = 409.0 Wh ≈ 0.41 kWh

$V=LxBxH^0$ Where Length $L=0.4m$. Breadth, $B = 0.3m$, Height $HF 0.35m$ $V=0.4\times0.3\times0.35. = 0.042m^3$.

Mass of mortar in Hopper: Given density of mortar: $P = 2200 \text{ Kg/m}^3$ $M=Pxv$ Mess = $2200\times0.042=9.2.4kg$.

Power Requirement Calculation

Force Required: $F=mg$. $F=92.4\times9.81=906.4N$

Torque Requirement Assume shaft radius $r = 0.05m$. $T=Fxr$ $T=906.4\times0.05=45.32Nm$.

Motor power Calculation motor Speed $N=300rpm$ Angular Velocity $w = 2\pi N\div60$, $w = 2\times3.142\times300\div60 = 31.42 \text{ rad/s}$

Power Required. $P=Txw$, $P=45.32\times31.42=1424W=1.42KW$

Applying safety factor: $1.42 \times 1.5=2.13KW$

Solar panel Sizing Calculation. Daily Energy required given: Power = 2.1kW, operating time = 4hour//day. $E=pxt=2.1\times4=8.4kWh = 8400Wh$.

Solar panel Requirement PSH = 5.5 hours/day. Accounting For 30% System losses: E required PSH = 5.5 h/day

System losses = 30%,

Efficiency = 70% = 0.7

Battery voltage=12V

$$\text{Required panel power (W)} = \frac{E}{\text{PSH X efficiency}}$$

$$\text{PSH x efficiency} = 5.5 \times 0.7=3.85$$

$$\text{Panel size (w)} = \frac{E}{3.85}$$

$$\frac{8400}{3.85} = 2182W$$

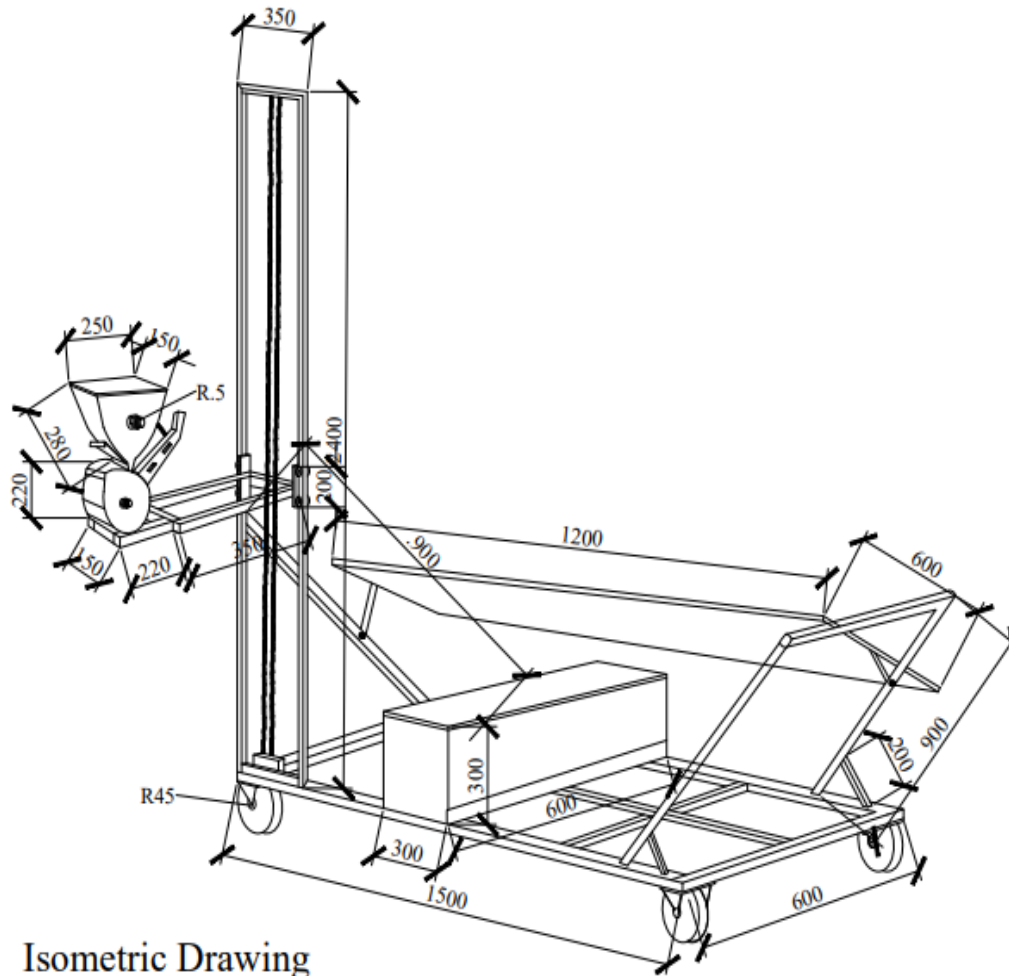

Questions 2: What are the Component Requirements for the Development of Solar-Powered Automated Tyrolean Sprayer for teaching finishing in brick/block laying and concreting in technical colleges in North-Central Nigeria?

Table 1 below showed the components required for the Development of Solar-Powered Automated Tyrolean Sprayer for teaching finishing in brick/block laying and concreting. Solar panel made of silicon is required, battery made of manganese, and electric motor made of silicon steel and copper, other components are solar charger controller, deep cycle battery, DC motor, motor controller, stranded cable, hopper, Tyrolean flicker, chain and sprocket, bolt and nut, bearing, wheel, rail and based are the basic component required for the development of Solar-Powered Automated Tyrolean Sprayer

Table 1: Component/Materials and Material Properties of solar-powered Automated Tyrolean sprayer

S/N	Components	Materials	Material Properties
1	Solar panel	Monocrystalline, polycrystalline silicon cells, tempered glass cover, aluminum frame, encapsulation polymer.	Convert sunlight into DC electricity, durable; weather-resistant,
2	Solar charger controller	Plastic/metal casing, electronic circuitry, capacitors, resistors, microcontrollers	Regulates current/voltage from solar panel to battery; prevents overcharging, deep discharge, and reverse flow
3	Deep cycle Battery	Lead plates and sulfuric acid electrolyte (lead-acid type)	Designed for repeated charge/discharge cycles, capacity measured in ampere-hours
4	DC Motor	Copper windings, permanent magnets or electromagnets, steel shaft, laminated steel core, aluminum/iron casing	Converts electrical energy (DC) to mechanical rotation; rated by voltage, current, RPM, torque.
5	Motor Controller	plastic, are copper and silicon	Strength, insulation, and heat dissipation, high electrical conductivity, insulation and durability).
6	Stranded Cable	Copper (preferred for conductivity), aluminum PVC/rubber insulation.	Flexible electrical conductor made of multiple small wires twisted together; resists bending fatigue. Rated by cross-sectional area (mm ²)
7	Hopper	mild steel	Durable, corrosion-resistant, and smooth to allow free flow of materials without clogging
8	Tyrolean flicker	aluminum or steel	corrosion resistance, durability and strength
9	Chain	Hardened alloy steel, stainless steel (for corrosion resistance).	Flexible mechanical linkage transmitting power between sprockets, high tensile strength
10	Sprocket	Hardened steel, cast iron, or sometimes engineering plastics (for light duty).	Toothed wheel designed to mesh with a chain; transfers rotary motion.
11	Bolt and Nut	carbon steel	High tensile strength, hardness, corrosion resistance alloy steels give extra toughness and fatigue resistance.
12	Bearing	Cast iron	High tensile strength, rotary motion.
13	Wheel	Rubber, steel	Structural strength and toughness, Rubber provides flexibility and grip, metals provide load-bearing capacity and resistance to deformation.
14	Rail	Mild steel	Hardness, wear resistance, ability to withstand heavy loads and impact without deformation
15	Based/Handle	Mild steel	provides good vibration damping and compressive strength

Source: Field Survey, 2025

Questions 3: What are the Construct procedures for the Development of Solar-Powered Automated Tyrolean Sprayer for teaching finishing in brick/block laying and concreting in technical colleges in North-Central Nigeria?

Construction Procedures of a Solar-Power Automated Tyrolean Sprayer involves several systematic steps that take the concept from design to physical, working hardware (Musa, 2022).The engineering procedures that guided the general construction pcedures are:

- i. Design and Planning: automatic based, CAD Modeling: engineering drawings, bill of materials (BoM)
- ii. Material Sourcing & Procurement: metal sections, power source,
- iii. Cutting & Machining: hacksaws, drilling, and grinding
- iv. Frame Fabrication: welding, grinding and finishing, reinforcement
- v. Assembly: mounting mechanisms ensure proper alignment and secure attachment.
- vi. Electricals: wire up motor, control switch, or starter (for powered systems).
- vii. Testing & Calibration: dry Run, adjust pressure as needed, measure output, check for shape accuracy, surface treatment, paint or powder coat, lubrication,

Component Parts of Solar-Powered Automated Tyrolean Sprayer.

Exploded view

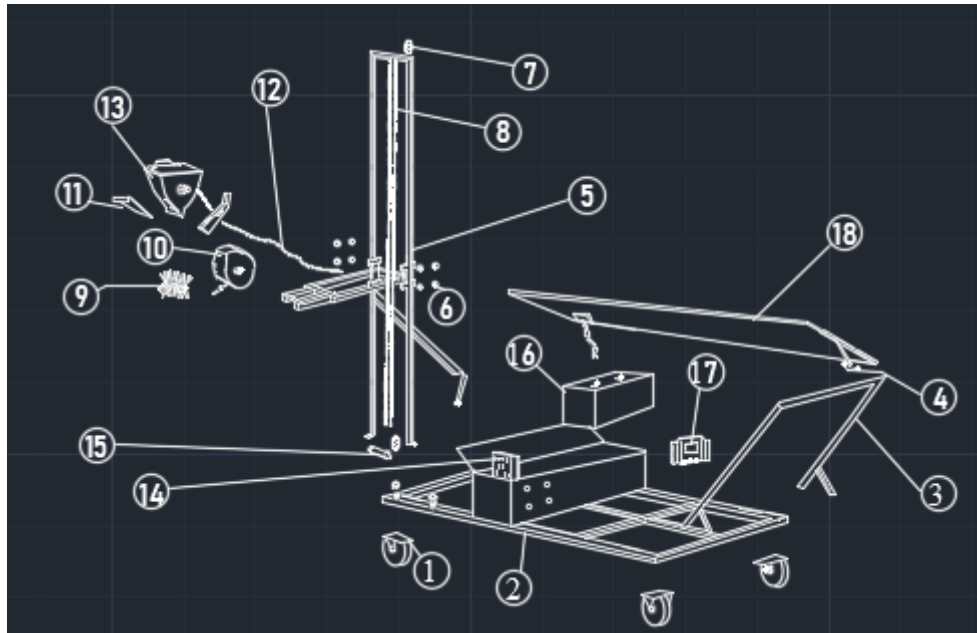

18	Solar Panel	Monocrystalline	200Ampere	1
17	Solar charger controller	Plastic	30 Ampere	1
16	Deep cycle battery	Lead plates and sulfuric acid electrolyte	120H	1
15	DC Motor	Copper winding, iron casting	1.5 Horse Power	2
14	DC Motor controller	Copper silicon and plastic casting	.05Horse Power	1
13	Hopper	Mild Steel	.05 Sheet metal	1
12	Stranded cable	Copper silicon and plastic casting	700mm	-
11	Hopper Controller	Mild Steel	.05mm sheet metal	1
10	Flicker gun	Mild Steel	.03mm sheet metal	1
9	Flicker Brush	Mild Steel	.02mm sheet metal	2
8	Chaine	Alloy Steel	600mm	2
7	Sprocket	Cast iron	31 & 14T	3
6	Bearing	Cast iron	20mm (R10)	11
5	Rail	Mild Steel	.05mm Square pipe	1
4	Bolt and Nut	Carbon Steel	Size 17 & 12	11
3	Handle	Mild Steel	.600mm	1
2	Based	Mild Steel	.05mm square pipe	4
1	Wheel	Rubber	900mm (R45)	4
S/N	COMPONENTS	MATERIALS	SIZE	QUNT
COMPONENT PARTS OF SOLAR POWERED AUTOMATED TYROLEAN SPRAYER				



Operational Procedure

The operation begins with the solar panel (photovoltaic module), which captures sunlight and converts it into direct current (DC) electricity using the principle of the photovoltaic effect. This generated electricity is then regulated by a charge controller, which ensures that the battery is charged efficiently while preventing overcharging or deep discharging (Abdullah, 2020). The operational procedure of a solar-powered automated Tyrolean sprayer is a step-by-step process for safe setup, operation, spraying, and shutdown of the sprayer. Below is a clear, engineering-based procedure for the operation of solar powered automated Tyrolean sprayer:

- i. . Pre-operational inspection: Check the solar panel for proper positioning toward sunlight, ensure the battery (if included) is fully charged, inspect all electrical connections (wires, controller, switches), check the DC motor, pump, and hopper for cleanliness and blockage, ensure the Tyrolean gun/nozzle is not clogged, verify the frame stability and tighten loose bolts.
- ii. System Setup and preparation: Mount or position the sprayer on a stable surface, fill the hopper with properly mixed mortar/rendering material, adjust material consistency (not too thick or too watery), switch ON the solar power control unit, confirm that power is being supplied from the solar system to the motor.
- iii. Power activation: turn ON the main power switch/control panel, allow the solar panel, charge controller, and battery system to stabilize, check that material flowing from hopper to nozzle.
- iv. Spraying operation: Hold or position the Tyrolean spray gun at a recommended distance (usually 0.5–1.5 m from wall), direct the nozzle evenly across the surface, maintain consistent motion, adjust pressure/speed using control settings if available, ensure uniform texture application on the wall surface.
- v. Monitoring during operation: Monitor solar power output (ensure no drop in voltage), observe motor temperature to avoid overheating, check for clogging in nozzle or hose, refill hopper when material reduces, maintain consistent spraying pressure for uniform finish.
- vi. Shutdown procedure: Turn OFF the motor and control switch. Allow system to stop completely before cleaning, empty remaining mortar from hopper.
- vii. Cleaning and maintenance: Wash hopper and nozzle immediately with clean water, remove any hardened material to prevent blockage, lean solar panel surface (dust reduction improves efficiency), Inspect moving parts for wear and tear, lubricate mechanical components if required.
- viii. Post-operation storage: store equipment in a dry, shaded area, protect solar panel from physical damage, and cover electrical components to prevent moisture exposure, record operational issues for maintenance log.

The operational of Solar-Power Automated Tyrolean Sprayer procedure focuses on: Inspection, Setup, Power activation, spraying, Monitoring, shutdown, and cleaning. The operational procedure ensures: Safety of operator, efficiency of solar energy use, and uniform wall finishing and long lifespan of equipment

Conclusion

The development of the solar-powered automated Tyrolean sprayer was guided by the specific objectives of identifying component requirements, establishing design criteria, and outlining a systematic construction procedure. Based on the findings, it was established that the successful operation of the system depends on the proper integration of key components such as

a photovoltaic solar panel, charge controller, rechargeable battery, DC motor, hopper unit, spray gun mechanism, and a stable supporting frame. These components were selected and sized to ensure compatibility, energy efficiency, and effective performance in delivering uniform Tyrolean finishes in brick/block laying and concreting applications. In relation to the design criteria, the study revealed that factors such as energy demand, load capacity, portability, operational efficiency, durability, and ease of maintenance were central to the development process.

The sprayer was designed to operate independently of grid electricity, making it suitable for technical college workshops and field applications where power supply may be unreliable. Emphasis was also placed on safety, mechanical stability, and sustainable energy utilization to enhance both instructional and practical effectiveness. The construction procedure demonstrated that the fabrication process involved sequential assembly beginning with the frame construction, followed by installation of the hopper, motorized spraying system, and electrical integration of the solar charging unit. Proper alignment, wiring, and testing were essential steps to ensure smooth operation and effective material discharge during Tyrolean finishing activities.

However, the study acknowledges certain limitations the absence of large-scale field testing under varied environmental and operational conditions. It is therefore recommended that future research should focus on comprehensive performance evaluation under real workshop and construction site conditions. Further studies should also explore improvements in energy storage capacity. The Development of Solar-Power into an Automated Tyrolean Sprayer will significantly reducing production costs, improve productivity, and enhance the quality of finishes, in brick/block laying and concreting in technical colleges in North-Central Nigeria.

Recommendations

The paper recommends the following:

- a. There is need to make policies and plan programs/projects that are aimed towards encouraging the development of Solar-Powered Automated Tyrolean Sprayer for finishing in brick/block laying and concreting in technical colleges.
- b. Collaboration between technical colleges and construction industries should be encouraged to refine the design and ensure the equipment meets real-world standards.
- c. Educational authorities should develop policies that support the integration of renewable energy-powered tools in technical colleges in North-Central Nigeria
- d. Government and educational stakeholders should provide funding for the mass production and distribution of the sprayer to technical colleges.
- e. Educational authorities should develop policies that support the integration of renewable energy-powered tools in technical education

References

- Abdullah, M. A. (2020). Development of solar-powered systems for construction technology applications. *International Journal of Engineering Research*, 9(4), 112–120.
- Akinwale, A., & Ogundari, I. (2017). Development of innovative construction tools for skill acquisition. *Journal of Technical Education* 12(2), 45–58.
- Hurst, K. (2018). Solar-powered automation in construction processes. *Journal of Construction Innovation*, 23(2), 99–113
- Musa, Y. (2022). Design and development of solar automated machines in developing countries. *International Journal of Sustainable Technology*, 18(2), 78–92.
- Nwankwo, S. (2021). Design and evaluation of solar-powered sprayers. *African Journal of Engineering Research*, 8(4), 200–214.
- Ogundero, I. B., Busari, R. A., Adebayo, K. R., Ore, A. A., Tsee, A. T., Sani, F. U., & Okoro, U. P. (2024). Design and development of solar powered sprayer. *International Journal of Modeling and Applied Science Research*, 6. <https://cambridgeresearchpub.com/ijmasr/article/view/418>
- Okoye, C. (2020). Photovoltaic systems in developing economies. *Energy Policy Journal*, 34(2), 88–101.
- Smith, P. (2019). Building finishes and surface treatments. *Journal of Architecture and Construction*, 22(1), 12–25.
- Ugochukwu, S. (2021). Finishing techniques in Nigerian construction. *Journal of Building Practice*, 15(2), 44–59.